

# HYGUARD® Safety Couplings

## Series BWN

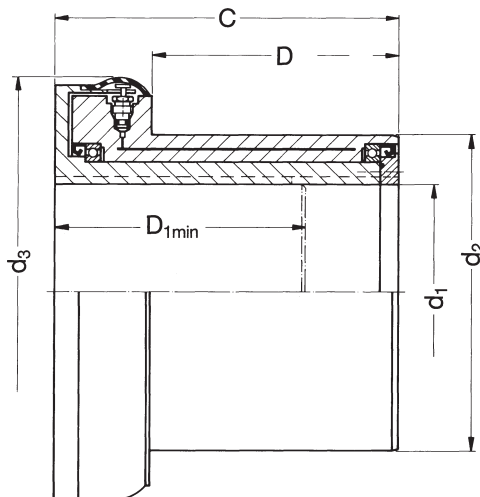

Table of Dimensions No. 243 083



The HYGUARD® BWN series is an extension of the BN series and is also equipped with an integrated keyway. It is therefore just as suitable for conversions as for new systems. Two roller bearings

are additionally incorporated, thus dispending with the limitation of the sliding velocity to 1.5 m/s. BWN models are therefore also suitable for higher-speed drives.

1) Higher speeds on request

**For surface roughness and tolerances, please see page 9.**

Dimensions are subject to change due to technical progress.

Type <b>BWN</b>	Torque Range T ~ Nm	Speed <sup>1)</sup> n <sub>max.</sub> rpm	Dimensions						Weight kg	Mass Moment of Inertia J kgm <sup>2</sup>
			d <sub>1</sub> mm	d <sub>2</sub> mm	d <sub>3</sub> mm	C mm	D mm	D <sub>1 min</sub> mm		
<b>50</b>	1700 – 3400	5300	40 – 50	80	138	105	67	80	5,7	0,011
<b>60</b>	2500 – 5000	5300	50 – 60	95	153	110	71	82	7,5	0,018
<b>70</b>	3750 – 7500	4500	60 – 70	110	166	125	83	105	10	0,031
<b>80</b>	6500 – 13000	3400	70 – 80	125	183	140	98	120	14	0,050
<b>90</b>	9000 – 18000	2800	80 – 90	145	201	160	113	130	20	0,093
<b>100</b>	11500 – 23000	2600	90 – 100	160	218	175	122	140	26	0,139
<b>110</b>	17000 – 34000	2600	100 – 110	175	228	190	137	145	31	0,197
<b>120</b>	20500 – 41000	2400	110 – 120	190	243	200	146	155	37	0,263
<b>130</b>	28000 – 56000	2000	120 – 130	205	256	220	164	160	44	0,345
<b>145</b>	35500 – 71000	1700	130 – 145	220	268	230	173	170	51	0,460
<b>155</b>	41000 – 82000	1600	140 – 155	240	286	260	193	180	69	0,721
<b>165</b>	55000 – 110000	1500	150 – 165	255	301	285	218	190	83	0,976
<b>185</b>	75000 – 150000	1500	160 – 185	280	333	300	233	210	113	1,65